

JUWEL - Schraubtechnik GmbH

Family business since 1980



PRODUCTS

Our motivation

Your application

Your problem solver in the field of torque bolting for over 40 years. Learn more about our torque wrenches up to 72,000 Nm and the matching accessories.

Product catalogue 2023



ABOUT US

In 1980, the company E. Berger & Söhne **JUWEL** - Schraubtechnik GmbH was founded by Ernst Berger and his sons Jochen and Siegfried. Over the years, a broad product portfolio has developed: We offer cordless torque wrenches with up to 10,000 Nm torque. Electric, pneumatic and mechanical torque wrenches are available with up to 15,000 Nm torque - hydraulic devices with up to 72,000 Nm. As your reliable partner, we also offer you impact sockets, Allen key holders and inserts, mounts, offset drives, reaction arms and much more. In addition, you can also obtain individual accessories from us. The dimensions? You decide. We manufacture exactly to your requirements in our own production facilities.

In combination with our services do our torque wrenches become the ideal products for your application. As a medium-sized family business, our communication channels are short and fast - the management is firmly integrated in the day-to-day operations. Our goal? To realise even the seemingly impossible screwdriving application together with you and to do so in the best possible quality: Modern CNC machining centres (3- and 5-axis CNC machines), high-quality alloys and a competent, well-coordinated team form the basis for excellent products and services from **JUWEL**. We are proud and pleased to know that some of our employees have been with us for over 35 years.

Our SERVICES

The screw connection - it finds its application in all industries. That's what makes our work and our products so exciting. There are bolting cases like in a textbook: torque wrench, standard reaction arm and impact socket: everything fits. But every now and then it is not so simple. Where can I put the reaction arm? How much space do I have for the socket? How tight is the screwdriving environment? Regardless of whether it's a standard or a special solution: we are right by your side and try to make everything possible. To do this, we come to your premises free of charge, assess

your current situation and then get to work. Our in-house design and CAD/CAM department will work out a specific solution and our sales department will be happy to advise you. Our service does not stop after the purchase: training, spare parts and repair service (also of other brands) and calibrations - all from one source. And we know no maintenance deadlines: even devices that are more than 20 years old will continue to be repaired and overhauled.



Engineer to Order

Thanks to our in-house CNC production, we manufacture products according to your requirements: reaction arms, nuts, offset drives, screw carriages and much more.



Consultation on site

Sometimes the best brochure and the most detailed homepage are sometimes just not enough: We will be happy to demonstrate our torque wrenches free of charge on your premises.



Calibration and repair

The first calibration is free of charge. Turnaround times for our workshop service are 7 working days (faster in urgent cases) - transitional equipment is available on request.



Certified JUWEL quality

All mechanical components are manufactured in Wissen an der Sieg in Rhineland-Palatinate. With the TÜV certification according to DIN ISO 9001, we successfully undergo an external audit of our quality standards every year.

CONTENTS



FAMILY BUSINESS _____	- 4 -
QUALITY AND DRIVE _____	- 5 -
BATTERY - TQS/TQWS/TQSM _____	- 6 -
ELECTRIC - TES/TEWS/TESM _____	- 12 -
PNEUMATIC - TL/TLW/TLM _____	- 18 -
MECHANICAL - TYP OX _____	- 22 -
BATTERY DIGITAL - TQX _____	- 25 -
HYDRAULIC _____	- 29 -
ENGINEER TO ORDER - ETO _____	- 31 -
IMPACT SOCKETS _____	- 34 -
REACTION ARMS _____	- 35 -
ALLEN HOLDER AND INSERTS _____	- 37 -
HOW TO ORDER _____	- 39 -
SERVICES _____	- 40 -

The author accepts no responsibility for the topicality, correctness, completeness or quality of the information provided. Liability claims against the author relating to material or immaterial damage caused by the use or non-use of the information provided or by the use of incorrect or incomplete information are excluded. The author expressly reserves the right to change, supplement, delete or temporarily or permanently cease publication of parts of the pages or the entire website without prior notice.

FAMILY BUSINESS

The company Ernst Berger & Söhne **JUWEL**-Schraubtechnik GmbH was founded in 1980 by Ernst Berger (see picture below) and his sons Jochen and Siegfried.



After manufacturing was initially carried out in rented rooms, the premises quickly reached their limits. The first new building began in the 1980s and laid the foundation for numerous expansions in the following decades.

Even today, the complete assembly and production is in Wissen.

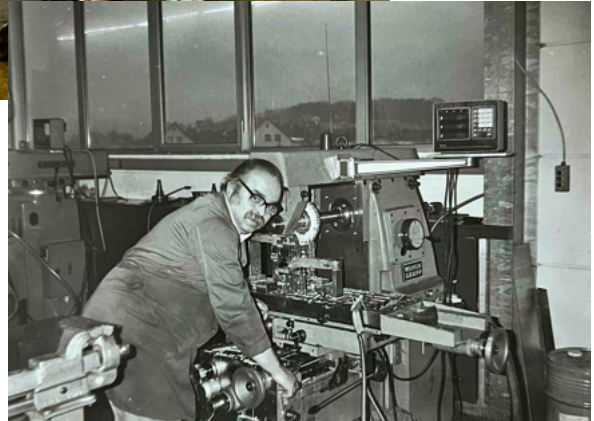

Over time, however, not only the building has evolved: The product portfolio and the workforce have also grown. After initially contract work and the mechanical torque wrench formed the heart of the company, electric, hydraulic and pneumatic torque wrenches were also manufactured by **JUWEL** due to the requirements of our customers and the developments in drive technology. In 2015, the battery-powered torque wrench was also introduced to the market. Thus, the TQS series forms a pioneering technology for the future orientation of our company.

We are particularly proud of the team behind the **JUWEL** brand: employees with many years of experience give their best every day to solve your challenges together with you - some of them for over 35 years now. Low staff turnover; employees who are happy to continue working even after retirement and motivated young colleagues expand and preserve the knowledge acquired over generations in the long term.

We maintain friendly relationships with customers and suppliers: Trust is the foundation of every relationship. But relationships need to be cared about. How? With communication! Please contact us at any time, regardless of your concern!

OUR MOTIVATION

We define ourselves as problem solvers in the field of bolting with torque wrenches. It is important to look at each bolting situation from the same objective starting point: „What torques are acting? How does the bolting environment react? Where can the reaction arm be put? Which drive makes the most sense? Which parts are connected with which screws?“, to name just a few examples of questions. This approach allows us and you to remain attentive and not overlook anything. This guarantees that you receive the right product and are satisfied in the long term.

Our heart of the company is our own production, construction and CAD/CAM programming. On the one hand, this enables us to offer short delivery times, on the other hand, we can produce any accessories for a safe bolting. No matter how impossible your bolting task seems - give us the chance to become your strong partner and together we will find a solution tailored to your needs. In addition to our torque wrenches, we also offer impact sockets, holders, reaction arms, adapters, mounts, Allen holders and inserts as well as offset drives from our own production.

OUR QUALITY

„We are happy to be your first partner for torque wrenches, but in any case we want to be your last.“ According to our philosophy, quality is mandatory for a long-term customer relationship. Only those who are satisfied with our products and service will be happy to return to us. Therefore, we have taken a number of measures over the years to ensure and guarantee high quality:

- Everything stands and falls with the quality of the gearbox. That is why we have made the strategic long-term decision to manufacture all mechanical components in our own company. For this purpose, we have more than 10 modern CNC machining centres and well-trained employees at our disposal.
- Our quality management must be constantly and independently checked: Several years ago, we were awarded the DIN ISO 9001 quality certificate. We successfully pass the external TÜV quality audit every year.
- Regional partners with the same quality standards: Suppliers who share the same drive for high-quality products are essential for machining processes that we have outsourced from our internal value chain. All surface treatments and heat treatments are carried out within a radius of 40 km by carefully selected long-term partners. Short communication channels enable a continuous and open exchange about common quality standards.

We look forward to your feedback so that we can continue to meet our and, above all, your demands for outstanding product and service quality.

BATTERY

With the launch of the TQS series in 2015, it was clear: this is the future. Since then, we have delivered hundreds of cordless torque wrenches worldwide. With an ear always close to the needs of our customers, the TQS has constantly evolved over the years: Today, 3 variants (straight, angled and multi) with up to 10 different performance models present themselves as the best-selling series of the **JUWEL** brand.

We rely on an intelligent gearbox system: the focus is on durability and reliability. How does this manifest itself in the technical implementation? Thanks to continuous research and improvement, we know which tooth flank width is necessary to transmit small and also large torques with minimal wear. Where others use just one gear, we prefer to use two. Every component is thought out down to the smallest detail: whether different alloys or the omission of castings. You benefit from an enormous longevity and low maintenance costs, as wear parts rarely need to be replaced - precisely and quickly.

The cordless torque wrenches are available from 100 to 10,000 Nm.



TECHNOLOGY

- 4 gears with 15 torque settings each
- Torques from 100 to 10,000 Nm
- Brushless PowerDrive Motor
- High speeds for fast screwing
- From TQS-400 (4,000 Nm) including additional handle for safe handling
- High-strength alloys ensure extremely long service lives under high loads
- Powerful battery technology with 6 Ah battery capacity: thanks to the quick charger, the batteries are fully charged again in less than 30 minutes
- Optional: Balancer Mount
- Torque accuracy of +/- 4 %
- Can also be combined with in-house produced offset drive (as an unit or flexibly interchangeable)



Scan and get more info about this product.

Tel. +49 2742 96 8 96 0
Fax +49 2742 96 8 96 22

info@juwel-schraubtechnik.de
www.juwel-schraubtechnik.de

Werkstraße 14
57537, Wissen, Germany

TQS - STRAIGHT

As the flagship of our company, the straight cordless torque wrench is one of the most popular products in our portfolio: In the range from 100 to 10,000 Nm, it is a true all-rounder. Whether in the small torque ranges (TQS-065 up to 650 Nm and TQS-095 up to 950 Nm) as a light assembly tool or for applications beyond 4,000 Nm - there are hardly any limits to our TQS.

It quickly became clear what possibilities the TQS with mobile drive source could offer users. Following specific enquiries, we were able to develop useful special models:

- TQS-Rim torque wrench (with extended housing and individual support on neighbouring screws)
- TQS-Gate valve machine (for the opening and closing of gate valves)
- TQS-Railway wrench (for safe and comfortable working in a standing position including suitable reaction arm)

ADVANTAGES



Intelligent weight distribution

Quality has weight - but you should never carry more than necessary: The models TQS-065 and TQS-095 are equipped with aluminium parts in appropriate places. Perfect for daily use on assembly lines.



Extreme durability of the gearbox

After decades in the field of bolting, we know where the loads are high and which parts are critical to failure: We use this knowledge for you and minimise the risk of failure by using high-strength alloys in the right place.



After-Sales Service

Our relationship does not end with the sale of a torque wrench; it begins. With us, you get full service including spare parts, calibrations, maintenance and accessories. The first calibration is free of charge!



Quality and power of the battery drive

Since the market launch, we have also relied on German partners in the field of battery technology. With the help of the quick charger, optimised efficiency of the gearbox and the powerful batteries (6 Ah), you can screw steadily.

TQWS - ANGLED



Should things ever get tighter, you'd better take a look at an angled torque wrench. For these screwing cases we have our TQWS: the angled cordless torque wrench. The performance data correspond to those of the TQS:

- Torques from 100 to 10.000 Nm

· 6 Ah Battery technology
With an additional handle on the angular gear, even larger torque wrenches can be easily placed on the screw. By

loosening the handle of the locking device, the complete drive unit can be freely rotated through 360°. In addition, the pistol grip can be rotated 360° and locked - individually adaptable to your spatial requirements.

For more information on the individual models, see page 9.

TQSM - MULTI



More flexibility is hardly possible: The multi-version of the cordless torque screwdrivers (TQSM) proves to be a true space miracle. Neither the straight nor the angled version is the ideal solution for your screwings? Instead of purchasing two devices, we can help you with the Multi-torque wrench. A design that was initially unique at the customer's request

has made it firmly into our portfolio due to increasing demand. Most of the time, the possibilities of the Multi version are not immediately imaginable, but after a demonstration, the enthusiasm is great. True German engineering in the form of a torque wrench. The TQSM models are available from 100 to 5,000 Nm.

More info on page 9.

MODELS

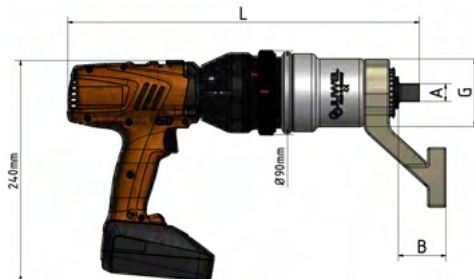

Models	TQS-065	TQS-095	TQS-130	TQS-220	TQS-300	TQS-400	TQS-500	TQS-600	TQS-700	TQS-1000
Square drive A	3/4"	3/4" / 1"	1"	1"	1"	1 1/2"	1 1/2"	1 1/2"	1 1/2"	1 1/2"
Item number	62 000 065	62 000 095	62 000 130	62 000 220	62 000 300	62 000 400	62 000 500	62 000 600	62 000 700	62 001 000
Torque (Nm)	100 - 650	100 - 950	100 - 1.300	100 - 2.200	100 - 3.000	150 - 4.000	250 - 5.000	350 - 6.000	450 - 7.000	1.050 - 10.000
Speed 1. gear (r/min)	8	7,5	4,25	2,1	1,2	1,25	1,25	1	0,75	0,4
Speed 2. gear (r/min)	16	15,5	8,5	4,2	2,5	2,5	2,5	2	1,5	0,75
Speed 3. gear (r/min)	36	35	20	8,5	6	5,5	5,5	4	3,5	1,75
Speed 4. gear (r/min)	70	36	39	18	12	11	11	8	7	3,5
Weight support (kg)	0,5	0,7	1,7	1,7	1,7	3,5	3,5	5,5	5,5	5,5
Weight (kg)	4,75	6,8	7,2	8,2	8,3	10,5	12,5	16	16	20
Length L (mm)	380	390/395	380	420	420	435	475	455	455	575
Width B (mm)	55	55/75	75	75	75	95	95	115	115	115
Ø Gear (mm)	75	75	88	88	88	99	99	135	135	135
Locking (mm)	90	90	90	90	90	90	90	90	90	90

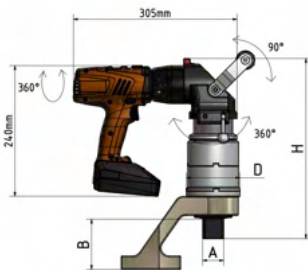

Modelle	TQWS-065	TQWS-095	TQWS-130	TQWS-220	TQWS-300	TQWS-400	TQWS-500	TQWS-600	TQWS-700	TQWS-1000
Square drive A	3/4"	3/4" / 1"	1"	1"	1"	1 1/2"	1 1/2"	1 1/2"	1 1/2"	1 1/2"
Item number	62 100 065	62 100 095	62 100 130	62 100 220	62 100 300	62 100 400	62 100 500	62 100 600	62 100 700	62 101 000
Torque (Nm)	100 - 650	100 - 950	100 - 1.300	100 - 2.200	100 - 3.000	150 - 4.000	250 - 5.000	350 - 6.000	450 - 7.000	1.050 - 10.000
Speed 1. gear (r/min)	8	7,5	4,25	2,1	1,2	1,25	1,25	1	0,75	0,4
Speed 2. gear (r/min)	16	15,5	8,5	4,2	2,5	2,5	2,5	2	1,5	0,75
Speed 3. gear (r/min)	36	35	20	8,5	6	5,5	5,5	4	3,5	1,75
Speed 4. gear (r/min)	70	36	39	18	12	11	11	8	7	3,5
Weight support (kg)	0,5	0,7	1,7	1,7	1,7	3,5	3,5	5,5	5,5	5,5
Weight (kg)	6	8,6	8,5	10,2	10,2	12	13,5	17	17	21
Length L (mm)	264	283 - 288	275	307	307	320	365	355	355	475
Width B (mm)	55	55/75	75	75	75	95	95	115	115	115
Ø Gear (mm)	75	75	88	88	88	99	99	135	135	135
Locking (mm)	90	90	90	90	90	90	90	90	90	90

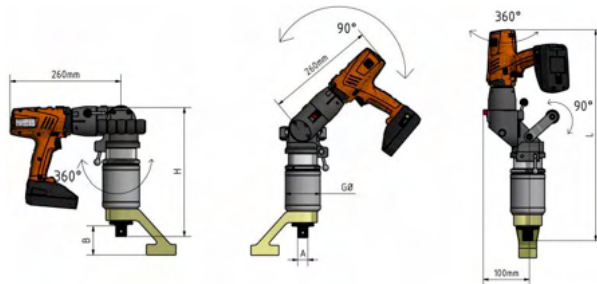

Modelle	TQSM-065	TQSM-095	TQSM-130	TQSM-220	TQSM-300	TQSM-400	TQSM-500
Square drive A	3/4"	3/4" / 1"	1"	1"	1"	1 1/2"	1 1/2"
Item number	62 200 065	62 200 095	62 200 130	62 200 220	62 200 300	62 200 400	62 200 500
Torque (Nm)	100 - 650	100 - 950	100 - 1.300	100 - 2.200	100 - 3.000	150 - 4.000	250 - 5.000
Speed 1. gear (r/min)	8	7,5	4,25	2,1	1,2	1,25	1,25
Speed 2. gear (r/min)	16	15,5	8,5	4,2	2,5	2,5	2,5
Speed 3. gear (r/min)	36	35	20	8,5	6	5,5	5,5
Speed 4. gear (r/min)	70	36	39	18	12	11	11
Weight support (kg)	0,5	0,7	1,7	1,7	1,7	3,5	3,5
Weight (kg)	7	9	9,1	10,4	10,5	12,7	13,9
Length L (mm)	500	510	510	530	530	555	605
Width B (mm)	55	55/75	75	75	75	95	95
Ø Gear (mm)	75	75	88	88	88	99	99
Locking (mm)	90	90	90	90	90	90	90

EXPLORE TQS



All cordless torque guns from the TQS-400 model upwards (max. 4,000 Nm) are equipped with an additional handle as standard. On the left: The TQS-700 (max. 7,000 Nm)



Steel construction: strong and welcome **JUWEL** customer. Requirements: In most cases, there are many bolted joints waiting for the assembly user. We will gladly advise you to find out which torque wrench is the right one for your application.

Curious for more? Arrange your free demonstration - digitally or at your location: sales@juwel-schraubtechnik.de



The cordless TQS rim wrench: Can also be used in tight spaces thanks to the extended housing. The special reaction arm enables support on adjacent screws: Safe and effective.



With the drive unit freely rotatable through 360°, you decide on the most comfortable grip for your application. This provides the basis for safe and ergonomic working.

MODELS IN DETAIL



TQWS-065

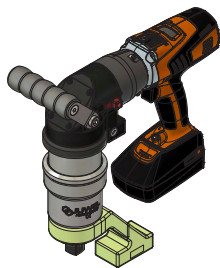

TQWS-095



TQWS-130 bis -300



TQWS-400



TQWS-500



TQWS-600 bis -700

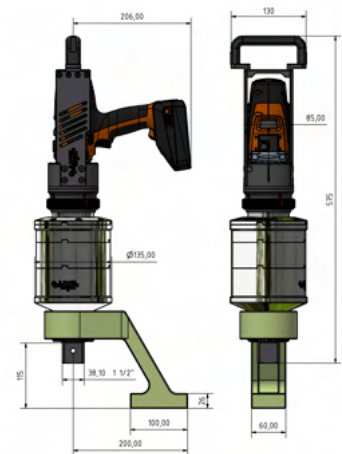

Maximum power! - The TQS-1000 bolts with up to 10,000 Nm! Also available in an angled version.

STEP models are available for every **JUWEL** torque wrench. Please contact us!

ELECTRIC

Powerful and reliable: With power wrenches of the TES series you can bolt electrically with up to 15,000 Nm torque. As with all **JUWEL** torque wrenches, 40 years of experience in gearbox construction are put to good use.

The electric (and pneumatic) torque wrenches have another special feature: We distinguish between standard and heavy-duty gearboxes. Where is the difference? Our standard models already meet our demands for high-quality and sustainable products. With the heavy-duty version, we take it to the extreme: the modular gearbox design (recognisable by the joints in the housing) allows the installation of additional bearings. This ensures extremely smooth running of the gearbox and makes the heavy-duty models the ideal tools for continuous and intensive assembly work. Why don't we build every torque wrench this way? Because of the bearings and the additional manufacturing effort, the heavy-duty models are more expensive and heavier. Not every customer needs such a tool - with us you only pay as much as you need for your application.



TECHNOLOGY

- Torques from 150 to 15.000 Nm
- 2 gears with a total of 200 torque settings allow fine adjustment of the torque required
- As 230V or 110V version available
- Accuracy of +/- 3.5 % for the same bolting case
- High speeds for fast and efficient bolting
- Free of charge and optionally available: Load breakaway. The torque wrench rotates a small number of degrees in the opposite direction to facilitate loosening the torque wrench.
- Control unit can be freely rotated through 360



Scan and get more info about this product.

Tel. +49 2742 96 8 96 0
Fax +49 2742 96 8 96 22

info@juwel-schraubtechnik.de
www.juwel-schraubtechnik.de

Werkstraße 14
57537, Wissen, Germany

TES - STRAIGHT

Even today, years after the introduction of cordless torque wrenches, electric power wrenches are still in demand. The advantages are obvious: remain independent of hydraulic torque wrenches up to 15,000 Nm. Avoid transporting a hydraulic pump and remain as flexible as possible up to 15,000 Nm. Similar to the TQS series, we also equip the TES models from a certain power class with an additional handle for better handling (from TES-505).

You need an extra measure of work safety? For this purpose, we equip our electric torque screwdrivers with an additional button for two-hand operation. After pressing the additional button, the screwing process begins. Furthermore, it is possible to equip all torque wrenches with a holder for balancers. This guarantees a maximum of ergonomics. The electric torque wrenches are also available as special models:

- TES-Seitenantrieb SAT: Seitenantriebe ermöglichen die Verschraubung versetzt zur Getriebeachse
- TES-Bahnschrauber (mit individuell bestellbarer Höhe der Getriebeeinheit und passender Abstützung)

ADVANTAGES

High Torques

Torques of up to 15,000 Nm are possible with the electric torque wrenches of the TES series. Without the use of pneumatics or pumps, you can carry out strong screw connections.

Extreme durability of the gearbox

We know where the loads are high and which gear components are critical to failure: We do not exploit this, but minimise the risk of failure through high-strength alloys and optimal tooth flanks.

After-Sales Service

Our relationship does not end with the sale of a torque wrench, it begins. We offer a full range of services including spare parts, calibrations, maintenance and accessories. The first calibration is free of charge!

JUWEL Load release

Optional: The electric torque wrench turns a small number of degrees in the opposite direction after successful screwing. This enables easy removal of the torque tool.

TEWS - ANGLED



Similar to the TQS series, the electric torque wrenches are also available as angled versions (TEWS). The performance data correspond to those of the TES:

- Torques up to 15,000 Nm with 2 gears and 200 torque settings
- 230 or 110 V version

The angled design allows the TEWS torque wrench to be used even under tight conditions, e.g. for flange bolting in pipe systems or for bolts

in production plants that are difficult to access. Furthermore, the additional handle on the angular gear facilitates the transport and handling of the torque wrench during bolting.

For more information on the individual models, see page 15.

TESM - MULTI



The Multi-Series (TESM) takes the decision between a straight and angled torque wrench away from you: Lock the drive unit as you need it. The possibilities are versatile:

- The complete drive unit can be rotated 360° around the gearbox axis
- The complete drive unit is adjustable by 90° from the gearbox

axis (i.e. change between straight and angled version as desired).

- The handle can be freely rotated 360° around the axis of the drive unit

The TESM models are available up to 5,000 Nm torque (TESM-505).

Learn more about the technical data on page 15.

MODELS



Models	TES-84	TES-104/105	TES-244/245	TES-354/355	TES-505	TES-604/605	TES-904/905	TES-1205	TES-1505
Square drive A	3/4" o. 1"	1"	1"	1 1/2"	1 1/2"	1 1/2"	1 1/2"	1 1/2"	2 1/2"
Item number heavy load A	-	50 105 110	50 245 120	50 355 130	50 505 140	50 605 150	50 905 160	50 915 170	50 915 180
Item number standard	50 084 100	50 104 110	50 244 120	50 354 130	-	50 604 150	50 904 160	-	-
Torque (Nm)	150 - 850	280 - 1200	360 - 2.500	360 - 3.500	700 - 5.000	816 - 6.000	1.024 - 10.000	1.024 - 12.000	1.440 - 15.000
Weight support (kg)	1,6	1,6	1,6	3,5	3,5	5,7	5,7	5,7	11
Weight standard (kg)	8/8,2	8,2	9,5	10,4	-	15,9	18,9	-	-
Weight heavy load (kg)	-	9,2	10,6	11,5	13,7	16,9	20,5	29	36
Height C (mm)	55-75	75	75	95	95	110	110	115	145
Heiht H (mm)	530/540	540	570	580	650	635	680	680	695
Idle speed (r/min)	16	14	10	9	3	6,5	2,5	2	2
Ø Gear standard (mm)	88	88	88	88	-	130	130	-	-
Ø Gear heavy load (mm)	-	99	99	99	99	135	135	172	172

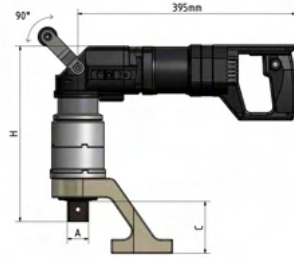

Models	TEWS-84	TEWS-104/105	TEWS-244/245	TEWS-354/355	TEWS-505	TEWS-604/605	TEWS-904/905	TEWS-1205	TEWS-1505
Square drive A	3/4" o.1"	1"	1"	1 1/2"	1 1/2"	1 1/2"	1 1/2"	1 1/2"	2 1/2"
Item number heavy load A	-	51 105 210	51 245 220	51 355 230	51 505 240	51 605 250	51 905 270	51 915 280	51 915 290
Item number standard	51 084 200	51 104 210	51 244 220	51 354 230	-	51 604 250	51 904 260	-	-
Torque (Nm)	150 - 850	280 - 1200	360 - 2.500	360 - 3.500	700 - 5.000	816 - 6.000	1.024 - 10.000	1.024 - 12.000	1.440 - 15.000
Weight support (kg)	1,6	1,6	1,6	3,5	3,5	5,7	5,7	5,7	11
Weight standard (kg)	9,5/9,7	9,9	11,5	12,3	-	18	20,8	-	-
Weight heavy load (kg)	-	11	12,5	13,3	-	18,8	22,4	31	38
Height C (mm)	55-75	75	75	95	95	110	110	115	145
Heiht H (mm)	265/275	275	305	315	365	350	390	400	415
Idle speed (r/min)	16	14	10	9	3	6,5	2,5	2	2
Ø Gear standard (mm)	88	88	88	88	-	130	130	-	-
Ø Gear heavy load (mm)	-	99	99	99	99	135	135	172	172



Models	TESM-84	TESM-104/105	TESM-244/245	TESM-354/355	TESM-505
Square drive A	3/4" o.1"	1"	1"	1 1/2"	1 1/2"
Item number heavy load A	-	50 105 113	50 245 123	50 355 133	50 505 140
Item number standard	50 084 103	50 104 113	50 244 123	50 354 133	-
Torque (Nm)	150 - 850	280 - 1200	360 - 2.500	360 - 3.500	700 - 5.000
Weight support (kg)	1,6	1,6	1,6	3,5	3,5
Weight standard (kg)	9,8/10	10	12,5	13,4	-
Weight heavy load (kg)	-	11,1	13,6	14,5	16,7
Height C (mm)	55-75	75	75	95	95
Heiht H (mm)	265/275	275	305	315	365
Idle speed (r/min)	16	14	10	9	3
Ø Gear standard (mm)	88	88	88	88	-
Ø Gear heavy load (mm)	-	99	99	99	99

EXPLORE TES



The straight electric torque wrenches can be equipped with an additional grip for ergonomic handling if required. Reach out to us - mounts can be designed to your needs.



There's no such thing as can't: Even when space is tight, we find a solution! The angled version of the electric torque wrench (TEWS) also adapts to tight spaces and enables you to screw (a special reaction arm was also used here).

Curiosity aroused? Arrange your free demonstration - digitally or at your location: sales@juwel-schraubtechnik.de



The multi-drive offers you maximum flexibility: adapt the drive unit to your environmental conditions and avoid investing in several torque wrenches when one can do everything!

All torque wrenches are manufactured and assembled in our company halls by the **JUWEL** team.



MODELS IN DETAIL

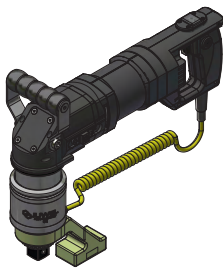

TEWS-084 bis -104



TEWS-245

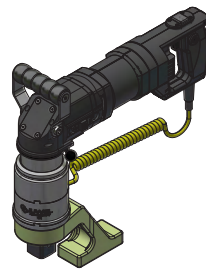

TEWS-355

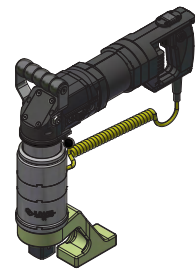

TEWS-505

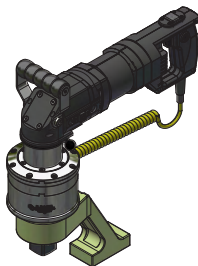

TEWS-605

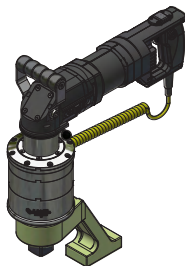

TEWS-905

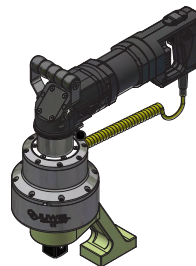

TEWS-1205

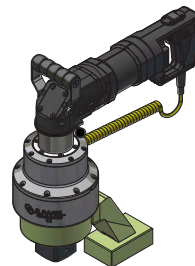

TEWS-1505

STEP models are available for every **JUWEL** torque wrench. Please contact us!

PNEUMATIC

Torques from 40 to 15,000 Nm are possible with **JUWEL** pneumatic torque wrenches. The pneumatically driven torque wrenches can achieve an accuracy of +/- 5% with a finely graduated pressure. The advantage of these torque wrenches lies in the characteristic of the drive medium: due to the compressibility of air, the required force can build up slowly and steadily. This makes it possible to retighten screws that have already been tightened without high wear. In addition, even hard bolts can be tightened without any problems.

The pneumatic drive is also characterised by vibration-free drive technology. Safe handling of the torque wrenches is supported by the ergonomically shaped handle and a user-friendly right-left switch.



TECHNOLOGY

- Torque from 40 to 15.000 Nm
- 2 Gears with a total of 44 torque settings allow fine adjustment of the required torque
- Fast gear and load gear
- Individual torque table: you give us your required torques and we provide you with the pressure equivalents
- Accuracy of +/- 5% for the same bolting case
- High speeds for fast and efficient bolting
- Control unit can be freely rotated through 360



More info about this product.

Tel. +49 2742 96 8 96 0
Fax +49 2742 96 8 96 22

info@juwel-schraubtechnik.de
www.juwel-schraubtechnik.de

Werkstraße 14
57537, Wissen, Germany

TL - STRAIGHT

Due to its compact design, even the straight version of the TL series is a flexible tool, even for tight screwdriving environments. The operating unit, which can be freely rotated through 360°, allows the handle to be positioned exactly where it is needed. The **JUWEL** pneumatic power screwdrivers are equipped with a robust steel support (see picture on the left). On request, individual reaction arms can also be manufactured according to your requirements.

Similar to the electric series TES, the pneumatic torque wrenches are also available in standard and heavy duty versions. For an explanation of the two versions, please see page 12.

ADVANTAGES

High Torques

With **JUWEL**'s in-house gearboxes, torques of up to 15,000 Nm are easily possible with the pneumatic power wrenches of the TL series.

Soft pneumatic drive

The smooth pneumatic drive also allows screws that have already been tightened to be tightened without any particular gear wear.

Exact Maintenance Unit

The adjustment via the finely graduated pressure reducing valve of the maintenance unit allows an accuracy of +/- 5% for the same screw case.

Highest gear quality

All mechanical components of **JUWEL** torque wrenches are manufactured in our own production halls. High-strength alloys and precise QM ensure the highest quality.

TLW - ANGLED



If even the compact design of the TL series does not meet your environmental requirements, the angled TLW series will be able to help you. The angled gearbox lets you screw without problems even in narrow environments. The additional handle guarantees safe handling even of torque wrenches with higher weights and torques. The

other technical data do not differ from those of the TL models. The ergonomic handle and the reliable and strong gear make the torque wrench a safe assembly tool with pneumatic drive.

For more information on dimensions and weights, see page 21.

TLM - MULTI



The Multi series of the pneumatic torque wrench is a true all-rounder. The following elements are individually adjustable: The complete drive unit can be rotated 360° around the gear axis. The pistol grip can also be freely rotated 360°. Finally, the drive unit can be adjusted 90° from the gear-box axis. This results in a large number of possible lockings. The Multi models of the pneumatic TL series are available up to a torque of 5,000 Nm. The multi-pneumatic screwdriver is particularly popular as an assembly tool in production lines: in combination with a balancer and the numerous locking options, you can screw quickly and easily.

For more information on dimensions and torques, see page 21.

Models

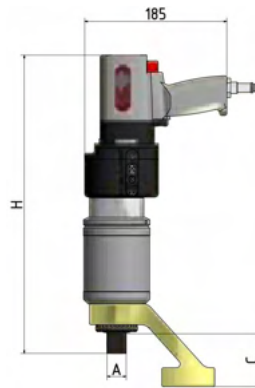

Models	TL-84	TL-104/105	TL-244/245	TL-354/355	TL-505	TL-604/605	TL-904/905	TL-1205	TL-1505
Square drive A	3/4" / 1"	1"	1"	1 1/2"	1 1/2"	1 1/2"	1 1/2"	1 1/2"	2 1/2"
Item number heavy load	-	56 105 000	56 245 000	56 355 000	56 505 000	56 605 000	50 905 000	50 120 000	56 915 000
Item number standard	56 084 000	56 104 000	56 244 000	56 354 000	-	56 604 000	56 904 000	-	-
Torque (Nm)	40 - 880	40 - 1.200	70 - 2.500	70 - 4.000	100 - 5.000	400 - 6.000	450 - 10.000	600 - 12.000	600 - 15.000
Weight support (kg)	1,6	1,6	1,6	3,5	3,5	5,7	5,7	5,7	11
Weight standard (kg)	6	7	7	8	-	12	16	-	-
Weight heavy load (kg)	-	8	8	9	9	13	17,6	18	34
Height C (mm)	55 - 75	75	75	95	95	110	110	115	145
Height H (mm)	360	360	410	410	460	420	460	470	500
Idle speed (r/min)	19	19	7,5	7,5	2	2,8	1,8	1,8	2
Ø Gear standard (mm)	88	88	88	88	-	130	130	-	175
Ø Gear heavy load (mm)	-	99	99	99	99	135	135	172	-

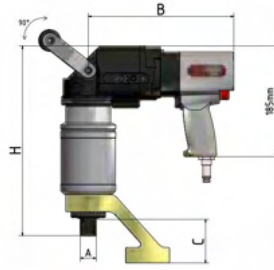

Models	TLW-84	TLW-104/105	TLW-244/245	TLW-354/355	TLW-505	TLW-604/605	TLW-904/905	TLW-1205	TLW-1505
Square drive A	3/4" / 1"	1"	1"	1 1/2"	1 1/2"	1 1/2"	1 1/2"	1 1/2"	2 1/2"
Item number heavy load	-	57 105 000	57 245 000	57 355 000	57 505 000	57 605 000	57 905 000	57 125 000	57 150 000
Item number standard	57 084 000	57 104 000	57 244 000	57 354 000	-	57 604 000	57 904 000	-	-
Torque (Nm)	40 - 880	40 - 1.200	70 - 2.500	70 - 4.000	100 - 5.000	400 - 6.000	450 - 10.000	600 - 12.000	600 - 15.000
Weight support (kg)	1,6	1,6	1,6	3,5	3,5	5,7	5,7	5,7	11
Weight standard (kg)	7	8	8	9	-	13	17	-	-
Weight heavy load (kg)	-	9	8,1	10,1	11	14	18,6	19	35
Height C (mm)	55-75	75	75	95	95	110	110	115	145
Height H (mm)	270	270	300	320	350	340	380	390	420
Idle speed (r/min)	19	19	7,5	7,5	2	2,8	1,8	1,8	2
Ø Gear standard (mm)	88	88	88	88	-	130	130	-	-
Ø Gear heavy load (mm)	-	99	99	99	99	135	135	172	175

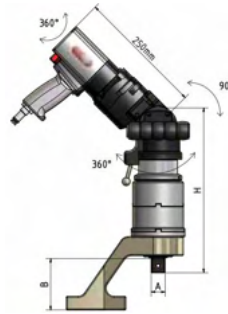

Models	TLM-84	TLM-104/105	TLM-244/245	TLM-354/355	TLM-505
Square drive A	3/4" / 1"	1"	1"	1 1/2"	1 1/2"
Item number heavy load	-	58 105 310	58 245 320	58 355 330	58 505 340
Item number standard	50 084 300	58 104 310	58 244 320	58 354 330	-
Torque (Nm)	40 - 880	40 - 1.200	70 - 2.500	70 - 4.000	100 - 5.000
Weight support (kg)	1,6	1,6	1,6	3,5	3,5
Weight standard (kg)	9/9,5	9,5	9,5	10,5	-
Weight heavy load (kg)	-	10,6	10,5	11,5	12,6
Height C (mm)	55/75	75	75	95	95
Height H (mm)	250/270	270	300	330	360
Idle speed (r/min)	19	19	7,5	7,5	2
Ø Gear standard (mm)	88	88	88	88	-
Ø Gear heavy load (mm)	-	99	99	99	99

MECHANICAL

Probably the oldest drive variant in **JUWEL**'s product portfolio: The mechanical torque wrenches of the Type-0X series. With physical strength and supported by the mechanical planetary gear, you can achieve torques from 160 to 15,000 Nm.

The decisive advantage of mechanical torque wrenches? Regardless of your technical equipment, you can always screw anywhere. Selected, high-strength alloys in conjunction with optimised tooth flank widths and a high degree of manufacturing accuracy still give the mechanical torque wrench its absolute advantage. Continuous enquiries and sales of the Type-0X series guarantee the mechanical torque wrench a firm place in the product portfolio. If you are not satisfied with the dimensions, please contact us: We have already designed some special models of the Type-0X series (e.g. short or long version).



TECHNOLOGY

- Torques from 160 to 15,000 Nm
- Easy changeover between clockwise and counter-clockwise rotation
- Accuracy of +/- 2% for the same bolting case
- Fine multi-tooth pick-up guarantees flexible positioning of the support
- Robust and extremely durable planetary gearbox with optimised tooth flank widths
- Handle receptacle made of high strength metal guarantees reliable and safe absorption of the force applied by the user
- Reliable support made of investment casting



More info about this product

Tel. +49 2742 96 8 96 0
Fax +49 2742 96 8 96 22

info@juwel-schraubtechnik.de
www.juwel-schraubtechnik.de

Werkstraße 14
57537, Wissen, Germany

TYPE OX

JUWEL mechanical power wrenches are still used today in a wide range of industries.

With the help of a torque spanner and the torque table, you can flexibly determine your required torques: You take the torque table in hand, search for the required initial torque and thus determine the corresponding torque value that you have to set on the torque spanner. In this way, you can bolt with an accuracy of +/- 2% with the same bolt case with torques of up to 15,000 Nm.

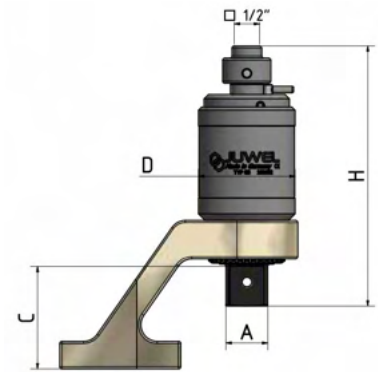

ADVANTAGES

High torques

Torques of up to 15,000 Nm are possible with the torque wrenches of the Type-OX series. This allows you to also tighten big screws without an energy source like electricity or hydraulic.

Full flexibility

The drive source? Your own physical strength, supported by the planetary gear. Full flexibility regardless of your technical equipment or location.

Cost-effective in use

According to the lack of drive, potential maintenance is reduced to the high-quality planetary gear. We don't worry much about that - and you don't have to either.

Individual constructions

Whether an extended and extra narrow housing, a more compressed design or a specific reaction arm. Please express your ideas!

Models	Type 01RS	Type 02K	Type 02	Type 03	Type 03L	Type 04	Type 06	Type 07	Type 08
Square drive A	1"	1"	1"	1 1/2"	1 1/2"	1 1/2"	1 1/2"	1 1/2"	2 1/2"
Item number	10 110 000	10 210 000	10 200 000	10 300 000	10 310 000	10 400 000	10 600 000	10 700 000	10 800 000
Torque (Nm)	160 - 1.200	540 - 3.200	540 - 3.200	540 - 4.200	1.460 - 5.400	680 - 6.200	1.860 - 10.000	1.900 - 10.000	1.900 - 15.000
Input size	1/2"	1/2"	1/2"	1/2"	1/2"	1/2"	1/2"	1/2"	1/2"
Weight reaction arm (kg)	1,6	1,6	1,6	3,5	3,5	5,7	5,7	5,7	11
Weight (kg)	3,6	5,9	3,7	5,9	7,5	10,8	15,8	19	31
Height C (mm)	55-75	75	75	95	95	110	110	130	145
Height H (mm)	180	340	225	235	375	365	315	328	340
Ratio	1:4	1:16	1:16	1:16	1:64	1:22	1:60	1:74,8	1:74,8
Ø Gear D (mm)	85	88	88	88	88	130	130	175	175



DID YOU KNOW?

Thanks to our in-house production, we are extremely flexible. This allows us short delivery times for both standard production and special solutions. From cutting the raw materials to assembling the final unit: all production and assembly steps take place in Wissen an der Sieg in Rhineland-Palatinate, DE.

What does that mean for you? Even in times of impaired supply chains, we are your reliable partner: Torque wrenches, slip-on nuts, Allen holders and nuts, supports, side drives, brackets, adapters and much more are available from the **JUWEL** brand.

BATTERY DIGITAL

Bolting meets Industry 4.0 - with the TQX series, the **JUWEL** brand is taking off digitally. With torques of up to 10,000 Nm, bolting operations can now be documented and evaluated sustainably.

With the TQX series we use two different digital drives: Up to 900 Nm we use a 20V drive - weight-optimised and light in the hand, the torque wrenches up to 900 Nm are ideal for daily assembly work. Above this torque value, we use a 40V drive: The flange adapted to the powerful gearboxes, the possibility to attach to a balancer and the usual **JUWEL** quality of gearbox technology make the TQX a high-end product around bolting. The functions are versatile: In addition to the use of the digital torque wrench, it is also possible to connect a central storage unit. In this way, the data of several TQX units can be stored.

TECHNOLOGY

- Torques from 50 to 10,000 Nm
- Extreme measuring accuracy by means of strain gauges
- Digital display for setting the torque/angle of rotation and programme selection
- Documentation of up to 1,200 bolting data (First-In-First-Out)
- Data transmission via Wi-Fi, Bluetooth or USB cable (optional with central control unit)
- App for Android/iOS devices and software for PC/laptop
- Up to 8 fixed programme steps (P1-P8) manually configurable
- Password protection adjustable
- Brushless motor



More info about this product

Tel. +49 2742 96 8 96 0
Fax +49 2742 96 8 96 22

info@juwel-schraubtechnik.de
www.juwel-schraubtechnik.de

Werkstraße 14
57537, Wissen, Germany

TQX 20V - FOR 900 Nm



Easy to use and versatile in its possibilities: the TQX is a true all-rounder when it comes to digital and documented bolting. You can bolt up to 900 Nm with the 20V version of the TQX. A low weight with the same technical possibilities meets the demand for assembly tools with low torques in terms of handling and functions. With the targeted use of aluminium components, additional weight is saved on power wrenches up to 900 Nm. Like the TQS, the TQX is available in straight, angled and multi versions.

Inquire now: sales@juwel-schraubtechnik.de

TQX 40V - FOR 10.000 Nm

Beyond 900 Nm, the 40V version of the TQX drive is used. The pre-equipment for attachment to a balancer and the robustly designed flange ensure safe handling even at high torques.

Thanks to the latest battery technology, you can screw up to 10,000 Nm smoothly and steadily. You can rely on the gear technology without the slightest worry: The planetary gear, which is also used in the other **JUWEL** devices, rounds off the TQX as a high-quality digital power wrench. We would be happy to offer you training on the functions of the TQX as part of a personal delivery.



TECHNICAL FEATURES



DOCUMENTATION OF SCREW DATA

Up to 1,200 bolting data are stored in the unit according to the first-in-first-out principle. The data can then be transferred to a smartphone, PC or storage unit.



TIGHTENING TORQUE

Do you have a target torque? With the TQX you can achieve the targeted torque quickly and accurately. Thanks to the highly accurate strain gauge, the tightening process meets the highest standards.



TIGHTEN ANGLE OF TWIST

In addition to tightening to torque, it is also possible to set a desired angle of rotation (alone or in combination with a required torque).



CUSTOMISED SCREW PROGRAMMES

Up to 8 tightening programmes can be set: e.g. 1,200 Nm and then 20°. The TQX carries out the instructions automatically. Switch conveniently between the programmes on the unit.



PROGRAMMIERUNG VIA SMARTPHONE

Whether Android or iOS smartphone: On the road, you can set up the TQX quickly and intuitively via smartphone. The connection is established via Bluetooth or USB cable.



PROGRAMMING VIA COMPUTER

We provide you with the software included with the drive free of charge. You can discover even more features of the TQX series on the computer: Change speeds or threshold torques, for example. We would be happy to train you!



INTERACTION WITH USER

The TQX takes the worry out of successful bolting: If the light is green, everything is OK. If the bolting is aborted or the final torque is outside the tolerance range you have set, the signal lights up yellow and you bolt again.



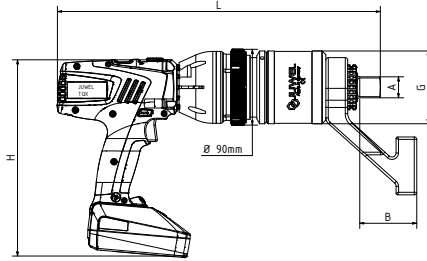

Models	TQX-060	TQX-090	TQX-130	TQX-220	TQX-300	TQX-400	TQX-500	TQX-600	TQX-1000
Square drive A	1"	3/4" o. 1"	1"	1 1/2"	1 1/2"	1 1/2"	1 1/2"	1 1/2"	1 1/2"
Item number	64 000 060	64 000 090	64 000 130	64 000 220	64 000 300	64 400 000	64 500 000	64 600 000	On request
Torque (Nm)	50 - 600	50 - 900	100 - 1.300	100 - 2.200	100 - 3.000	150 - 4.000	250 - 5.000	350 - 6.000	
Speed (r/min)	10	8	16	6,5	4,5	3,8	2	3,3	
Weight reaction arm (kg)	1,6	1,6	1,6	3,5	3,5	5,5	5,5	5,5	
Weight (kg)	4,25	6,3	9,1	10,8	10,8	12,6	14,1	17,6	
Length H (mm)	370	390	415	455	455	470	510	490	
Width B (mm)	55	55/75	75	75	75	95	95	115	
Ø Dear (mm)	75	75	88	88	88	99	99	135	
Ø Locking (mm)	90	90	90	90	90	90	90	90	

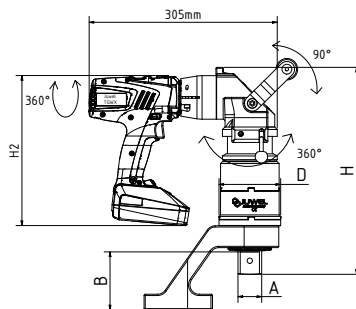

Models	TQWX-060	TQWX-090	TQWX-130	TQWX-220	TQWX-300	TQWX-400	TQWX-500	TQWX-600	TQWX-1000
Square drive A	1"	3/4" o. 1"	1"	1 1/2"	1 1/2"	1 1/2"	1 1/2"	1 1/2"	1 1/2"
Item number	64 100 060	64 100 090	64 100 130	64 100 220	64 100 300	64 100 400	64 100 500	64 100 600	On request
Torque (Nm)	50 - 600	50 - 900	100 - 1.300	100 - 2.200	100 - 3.000	150 - 4.000	250 - 5.000	350 - 6.000	
Speed (r/min)	10	8	16	6,5	4,5	3,8	2	3,3	
Weight reaction arm (kg)	1,6	1,6	1,6	3,5	3,5	5,5	5,5	5,5	
Weight (kg)	5,5	8,1	9,1	10,8	10,8	12,6	14,1	17,6	
Length H (mm)	264	283 - 288	275	307	307	320	365	355	
Width B (mm)	55	55/75	75	75	75	95	95	115	
Ø Gear D (mm)	75	75	88	88	88	99	99	135	
Ø Locking (mm)	90	90	90	90	90	90	90	90	

HYDRAULIC

BT-Series (Square drive)

- Accuracy +/- 3% for the same bolting case
- Torques 110 to 72,000 Nm
- Housing made of robust titanium-aluminium
- Square drive easily exchangeable
- 360° x 180° rotatable oil inlet ports
- Torque table engraved on unit
- Optional: matching pump, slip-on nuts, hoses and support

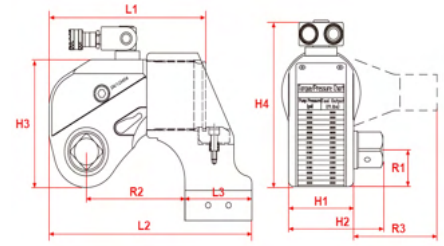

Models	BT-11	BT-18	BT-45	BT-75	BT-107	BT-155	BT-266	BT-347	BT-487	BT-720
Square drive	3/4"	3/4"	1"	1 1/2"	1 1/2"	1 1/2"	2 1/2"	2 1/2"	2 1/2"	2 1/2"
Item number	72 011 000	72 018 000	72 045 000	72 075 000	72 107 000	72 155 000	72 266 000	72 347 000	72 487 000	72 720 000
Torque (Nm)	110 - 1.100	180 - 1.850	430 - 4.500	740 - 7.500	1.000 - 10.700	1.550 - 15.500	2.600 - 26.600	3.400 - 34.700	4.800 - 48.000	7.200 - 72.000
Weight (kg)	1,8	2,5	5	8	11	15	26,5	35	50	87
H1 (mm)	42	50	68	80	90	100	120	137	153	160
H2 (mm)	66	72	95	123	134	142	183	200	216	223
H3 (mm)	77	96	127	149	167	182	220	247	282	291
H4 (mm)	109	131	177	199	217	232	270	297	332	341
L1 (mm)	111	145	178	211	222	246	308	323	373	400
L2 (mm)	140	173	229	271	293	318	384	401	497	516
L3 (mm)	46	59	75	87	93	105	126,5	129,5	193	159,5
R (mm)	75	92	124	140	165	178	213	228	244	258
R1 (mm)	21	26	34	39	47	51	59	66	77	81
R2 (mm)	69	85	114	137	153	154	186	199	214	259
R3 (mm)	54	66,5	89,5	100	120	128	153	159,5	167	178

KS-Series (Cassette)

- Constant repeatability of +/- 3%.
- Torques from 230 to 44,500 Nm
- Cassettes available in the range from 19 to 175 mm
- Can be used with square and hexagonal drives
- Ideal for heavy duty applications
- Everything from a single source: pumps, hoses and reducers

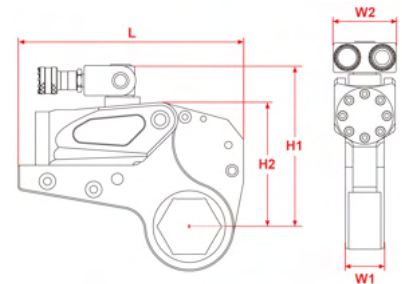

Models	KS-23	KS-24	KS-58	KS-64	KS-109	KS-117	KS-185	KS-418	KS-445
Torque (Nm)	230 - 2.300	240 - 2.400	585 - 5.850	645 - 6.475	1.095 - 10.940	1.175 - 11.775	1.850 - 18.500	4.180 - 41.800	4.450 - 44.500
Weight housing (kg)	1	1	2	2	3,3	3,3	5,5	11,4	11,4
Weight cassette (kg)	1,6	1,7	4,4	4,6	8,0	8,4	11,6	29	30
H1 (mm)	126	128,5	177	187	207	216	239	303	315
H2 (mm)	102,5	105	138	146	169	178	204	272	285
L (mm)	196	196	245	246	300	301	361	430	441
Hexagon (mm)	19 - 55	60	34 - 65	70 - 80	41 - 95	100 - 105	50 - 117	85 - 155	160 - 175
W1 (mm)	32	32	42	42	53	53	64	85	85
W2 (mm)	51	51	66	66	83	83	99	131	131

OFFSET DRIVE

Our electric, battery-operated and pneumatic torque wrenches can be combined with a side drive: fixed or freely interchangeable.

After several enquiries from our customers, three central types of side drive have emerged as standard variants: SAT-40, SAT-60 and SAT-90. Of course, other side drives can also be manufactured individually in our in-house production according to your requirements.

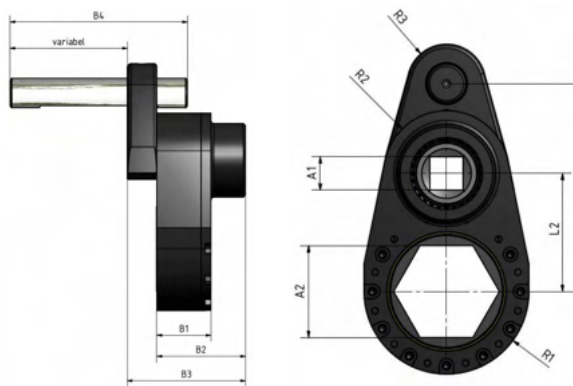

TECHNOLOGY

With the offset drive can also be screwed offset to the gearbox axis. We distinguish between three standard sizes of side drives:

- SAT-40 (max. 1,500 Nm)
- SAT-60 (max. 3,000 Nm)
- SAT-90 (max 5,000 Nm)

After exchanging your individual measurements (STEP models), we will be happy to get to work and manufacture a new side drive just for you.

Models	SAT-40	SAT-60	SAT-90
R1 (mm)	60	65	85
R2 (mm)	50	48	65
R3 (mm)	25	30	35
A1 (mm)	1"	1" - 1,5"	1" - 1,5"
A2 (mm)	SW 36-60	SW 55-70	SW 60-90
L1 (mm)	170	170	230
L2 (mm)	85	100	140
Gewicht (kg)	4,5	6,75	10
B1 (mm)	40	55	60
B2 (mm)	77	97	95
B3 (mm)	90	125	125
B4 (mm)	150	160	200

ENGINEER TO ORDER

As a rule, more is possible than our customers and interested parties assume at the beginning. In particular, interested parties who have not yet had any contact with the topic of torque wrenches are usually unsure whether and how a successful bolting operation can be implemented.

„What is a reaction arm? What is it needed for and where can I fit it? The standard nut from the catalogue doesn't fit, no standard torque wrench on the market has room in my bolting environment.“ We would like to get these questions and concerns out of the way right in the first conversation with you. You have the technical challenge, we have the knowledge and the manufacturing capabilities to overcome it together with you. Don't worry about horrendous prices: The quotation is transparent and is discussed with you in detail and substantiated with technical explanations.

PROCEDURE



You tell us your requirements: Torque, desired drive type, screw type, description of your application, drawings/sketches and/or STEP models.



We discuss possible solutions in close consultation with you. We recommend the best implementation based on over 40 years of experience with torque bolting.



After determining the possible solutions, we prepare a transparent offer including delivery times.



Everything OK? You give us your approval and we get to work. We will gladly deliver the (special) solution and train you and your team.

CASE

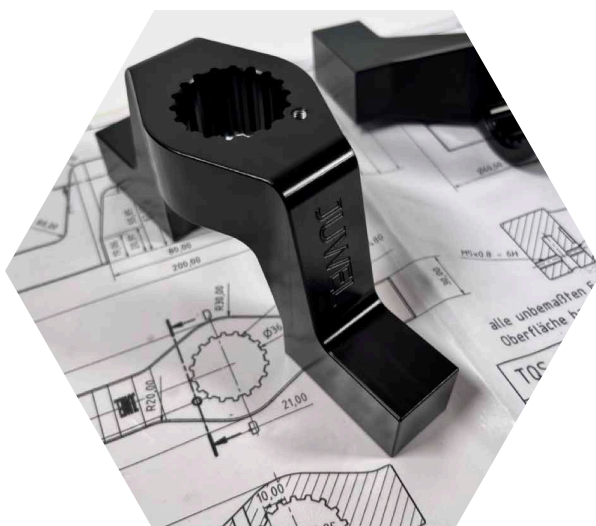

After the delivery of a battery-operated torque wrench, we promptly received an enquiry whether it was also possible to manufacture an individual reaction arm. The current support fits, but it could be even better. At that point, the ambition of our technical team was already aroused. After the problem-free exchange of STEP models, work could begin: Analyze the limitations of the

bolting environment, create a suitable design (in this case, a two-armed support that guarantees additional safety and support for the end customer), write the programme for the CNC machine, saw the aluminium and put it in the machining centre. Afterwards, the hard coating was applied by a regional partner: the reaction arm is ready and off to dispatch.

MORE PROJECTS

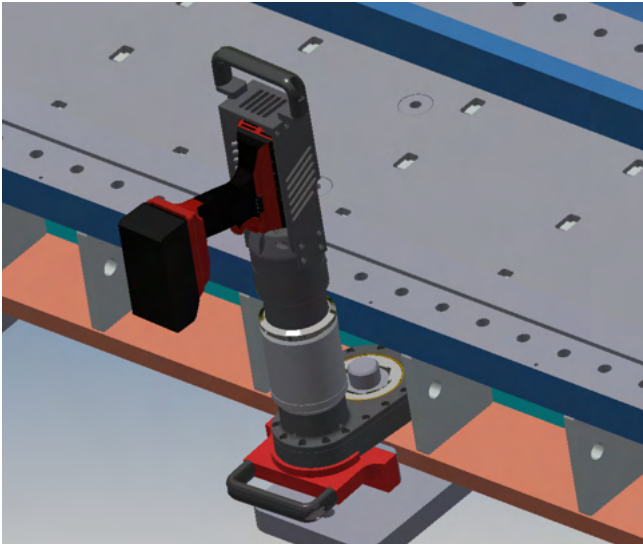

Individual offset drive with special support and handle for safe handling. All components were custom-made by **JUWEL**.

Double drive with automatic freewheel to find the screw position. Disassembly of engine connecting rods of large engines.

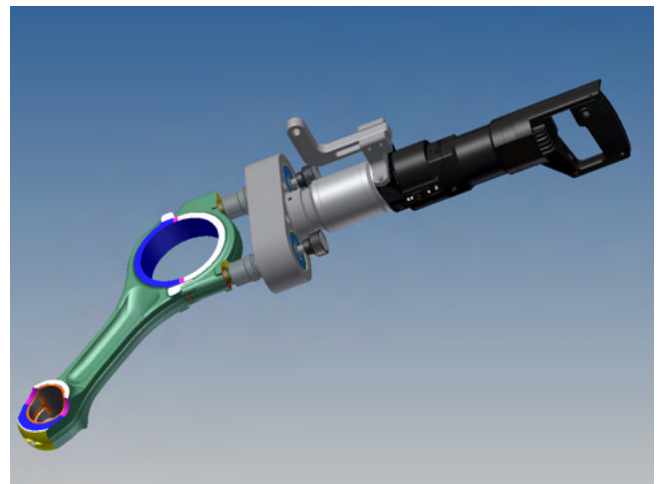

Special drive with Allen holder and insert including specific support for the (dis)assembly of chisels.

This is only an excerpt from countless special solutions for our customers. At first glance, we see no limits to your application: every bolting case should be made possible. Give us a chance!

TQS-1000

THE STRONGEST TQS EVER

- Torque range from 1,050 to 10,000 Nm
- 4 gears with 15 torque settings each enable a speed of up to 3.5 revolutions per minute
- Torque accuracy of +/- 4
- Brushless PowerDrive Motor
- Additional handle for safe handling
- High-strength alloys of the gear parts ensure extremely long operating times under heavy loads
- Modular heavy-duty gearbox now also in use with the TQS: Additional bearings ensure smooth running of the gearbox. Benefit from the reliability of **JUWEL** gearboxes
- Powerful battery technology from Germany (6 Ah)
- Full battery capacity within 30 minutes thanks to quick charger
- Optional: Balancer holder for ergonomic handling
- Special support for high torques

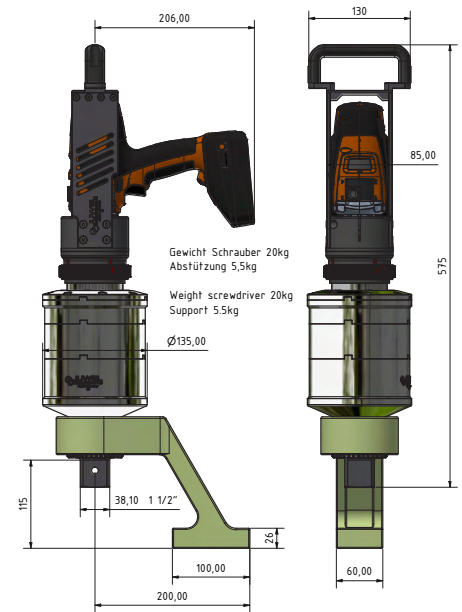

TEST OUR TQS-1000
DURING A FREE
DEMONSTRATION

ADVANTAGES

- Mobile bolting with up to 10,000 Nm torque
- No cables or hoses to get in the way during use
- Maximum reliability thanks to **JUWEL** heavy-duty gear technology

LEAN MORE



Scan the QR
code and go
to the product
page!

IMPACT SOCKETS

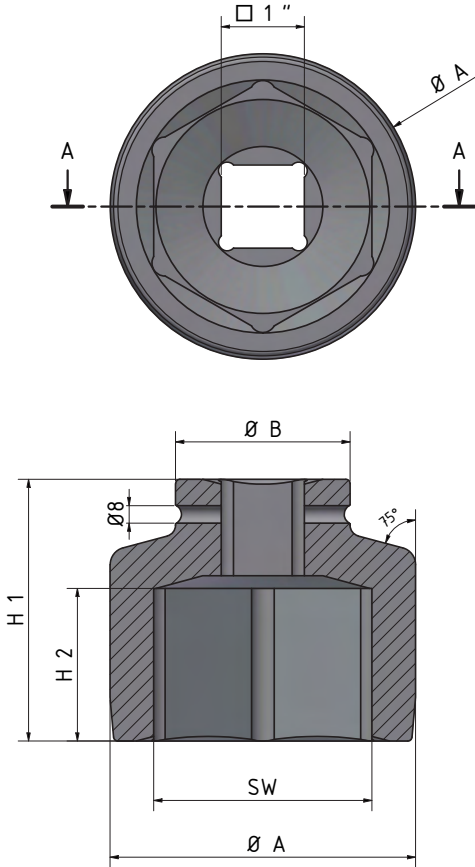

Aufstecknüsse 1 " / Impact Sockets 1"

Art. Nr.	Gewinde mm	Schlüssel- Weite* mm	Aufstecknuss				Gewicht Kg
			(ØA) mm	Maße (ØB) mm	(H1*) mm	(H2*) mm	
30 030 017	M10	17	32	54	15	57	0,58
30 030 019	M12	19	34	54	16	57	0,60
30 030 022	M14	22	39	54	16	57	0,61
30 030 024	M16	24	41	54	16	57	0,62
30 030 027	M18	27	45	54	16	57	0,63
30 030 030	M20	30	49	54	21	62	0,65
30 030 032	M22	32	51	54	21	62	0,68
30 030 036	M24	36	56	54	22	62	0,70
30 030 041	M27	41	63	54	25	66	0,85
30 030 046	M30	46	69	54	30	70	1,00
30 030 050	M33	50	74	66	35	70	1,10
30 030 055	M36	55	80	66	39	75	1,25
30 030 060	M39	60	86	66	40	75	1,40
30 030 065	M42	65	92	66	40	75	1,55
30 030 070	M45	70	99	66	40	75	1,65
30 030 075	M48	75	105	86	40	80	2,65
30 030 080	M52	80	110	86	45	85	2,95
30 030 085	M56	85	115	86	45	90	3,35
30 030 090	M60	90	123	86	45	95	3,85
30 030 095	M64	95	130	86	45	100	4,50
30 030 100	M68	100	136	86	50	100	5,00

* Aufstecknüsse sind in allen erforderlichen Längen gemäß Kundenvorgabe, als Sonderanfertigung lieferbar.

* Sockets are available in all required lengths according to customer specifications, available as a special order.

* Aufstecknüsse sind auf Anfrage in allen SW Zwischengrößen lieferbar.

* Sockets are available in all SW intermediate sizes on request.

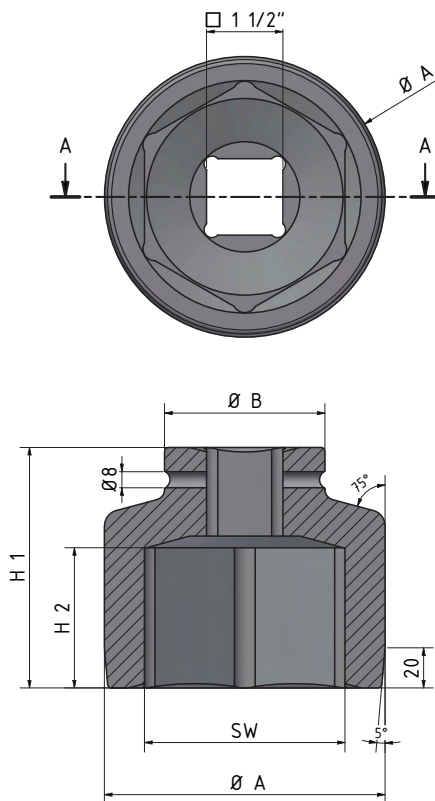

Aufstecknüsse 1,5 " / Impact Sockets 1,5"

Art. Nr.	Gewinde mm	Schlüssel- weite mm	Aufstecknuss				Gewicht Kg
			(Ø A) mm	Maße (Ø B) mm	(H1*) mm	(H2*) mm	
30 040 036	M24	36	65	86	115	20	1,8
30 040 038	M25	38	67	86	115	22	1,8
30 040 041	M27	41	71	86	115	25	2,2
30 040 046	M30	46	78	86	115	30	2,4
30 040 050	M33	50	83	86	115	32	2,4
30 040 055	M36	55	89	86	115	35	2,4
30 040 060	M39	60	96	86	115	40	3,2
30 040 065	M42	65	99,5	86	115	40	3,2
30 040 070	M45	70	108	86	115	45	3,8
30 040 075	M48	75	114	86	115	47	3,8
30 040 080	M52	80	119	86	115	50	4,6
30 040 085	M56	85	128	86	115	52	4,6
30 040 090	M60	90	134	86	115	55	6
30 040 095	M64	95	139	125	115	57	8,4
30 040 100	M68	100	146	125	115	60	9,2
30 040 105	M72	105	154	125	115	62	10,4
30 040 110	M76	110	159	125	120	65	10,4
30 040 115	M80	115	164	125	120	70	12,2
30 040 120	M85	120	174	125	120	75	14,4
30 040 125	M85	125	185	125	125	80	15,6
30 040 130	M90	130	185	125	125	82	15,6
30 040 135	M90	135	190	125	125	85	15,6
30 040 140	M90	140	195	125	130	87	16,6
30 040 145	M100	145	205	125	130	90	20
30 040 150	M100	150	205	125	130	90	20

* Aufstecknüsse sind in allen erforderlichen Längen gemäß Kundenvorgabe, als Sonderanfertigung lieferbar.

* Sockets are available in all required lengths according to customer specifications, available as a special order.

* Aufstecknüsse sind auf Anfrage in allen SW Zwischengrößen lieferbar.

* Sockets are available in all SW intermediate sizes on request.

Your size is not listed? Please contact us - we will be happy to manufacture a slip-on nut with a specific spanner size and length for you. 3/4" to 1 1/2" nuts are available from stock and 2 1/2" nuts on request.

REACTION ARMS

Vertically extended foot

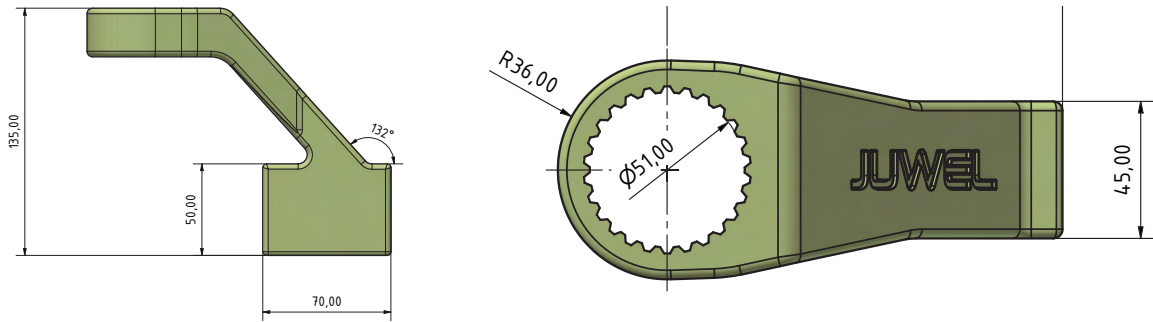

Horizontally extended foot

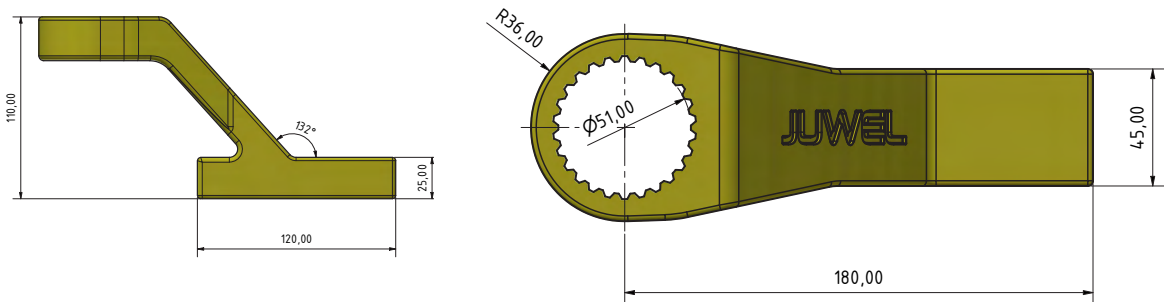

Sliding variant

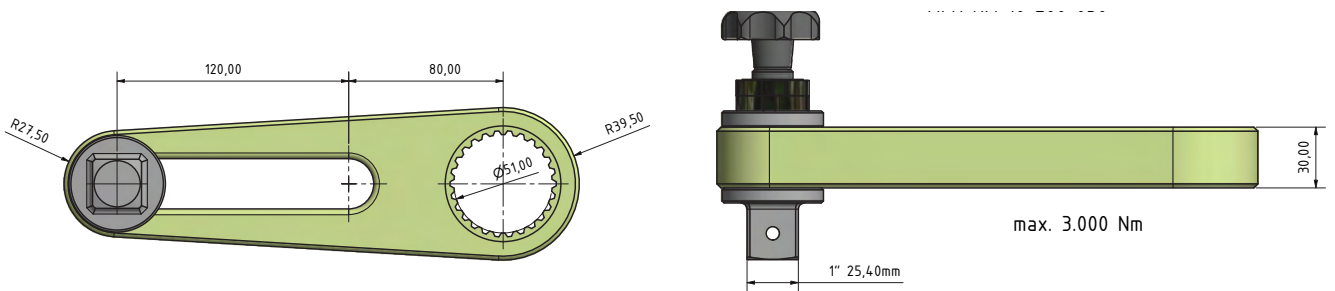

With pin

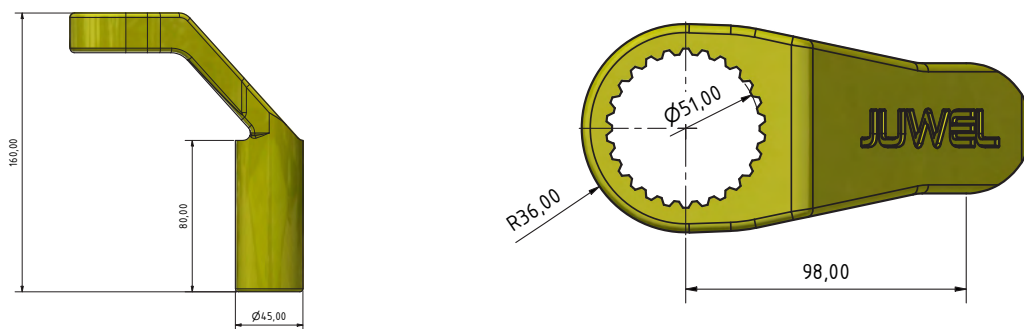

The dimensions do not fit your application exactly? No problem! Thanks to our own production, we are flexible and adapt to you and your application.

REACTION ARMS

Other previous special models

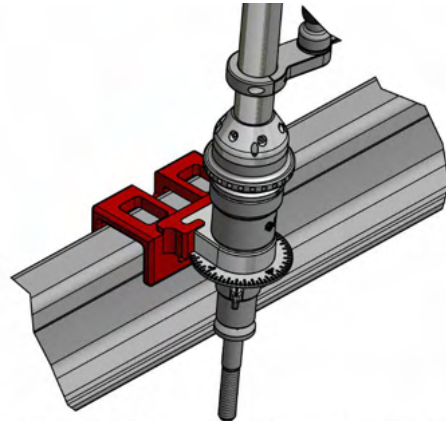
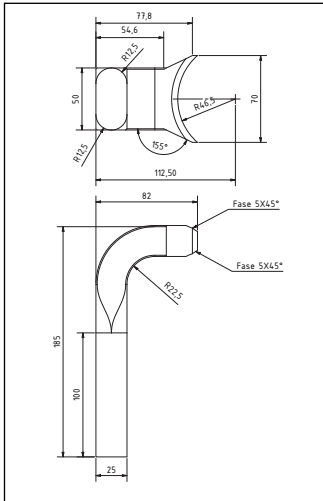

Sonderabstützung Schienenprofil mit Schleppeizer und Winkelscheibe, zur Drehmoment und Drehwinkel Überwachung.
Special support rail profile with pointer and angle indicator disk, For torque and rotation angle monitoring.

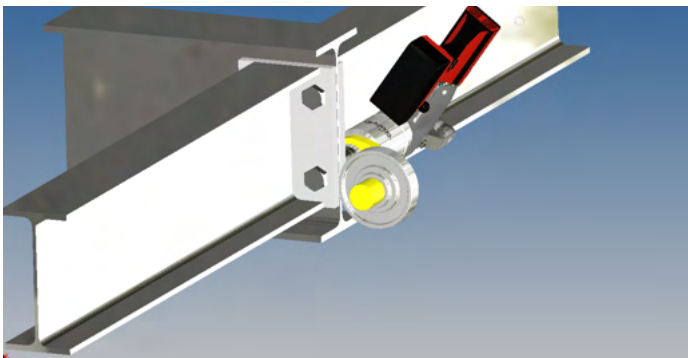

The customer's request: A cordless torque wrench with a reaction arm for all screw connections on changing beams. A wish we would like to realise, even if you sometimes have to think around the corner.

After first looking at the assembly in person, STEP models were exchanged. This enabled us to design a reaction arm with a pin and with exchangeable flanges: A reaction arm with many options.

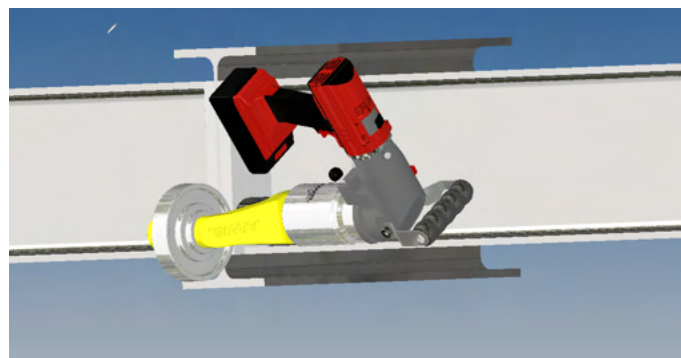

Send your enquiry regarding your support to sales@juwel-schraubtechnik.de

Should you already have drawings and models, then please send them along.

Your special support is not included? You have a specific application for which a standard solution does not help? We'll take a look at it.

ALLEN HOLDER AND INSERTS

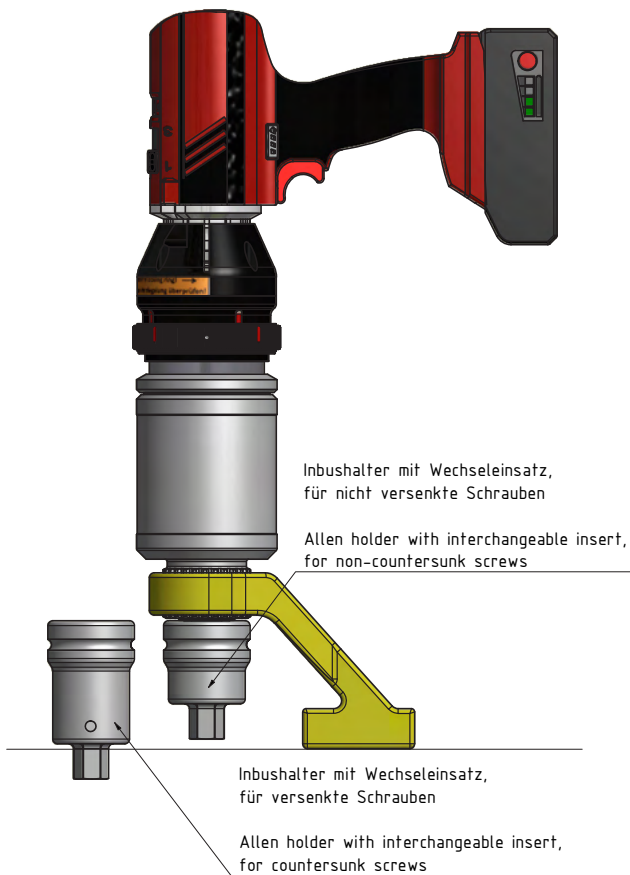

With Allen inserts, you can also screw Allen screws with a powerful torque wrench without any problems. You can choose between our standard and premium inserts and we will advise you on which version is suitable for you. The premium inserts are made of a special alloy with heat treatment.

The hexagon socket holders are adapted to your screw type: Please let us know whether you use countersunk or non-countersunk screws.

You tell us your required screw sizes and we will manufacture the appropriate Allen holder. You can then reduce from the initial spanner size of the holder to smaller spanner sizes without any problems.

JUWEL Allen inserts are made from high-strength alloys and then heat-treated for a longer service life.

Send your enquiry to sales@juwel-schraubtechnik.de

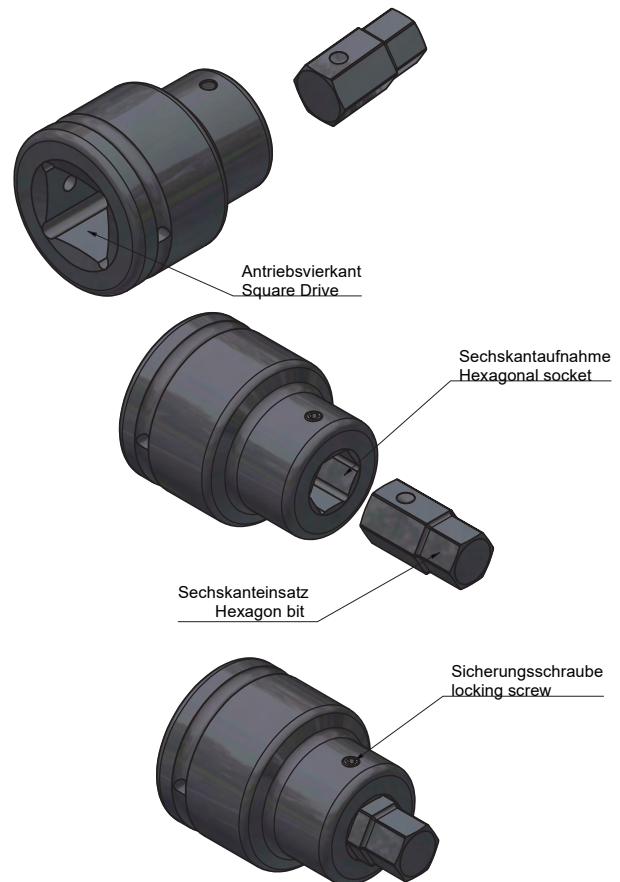

All Allen key holders and inserts are customised to your requirements: Please tell us your spanner sizes and spatial dimensions for the suitable length.

HOW TO ORDER

Inform yourself about our product portfolio with the help of our catalogue, the homepage and the data sheets. The accessories in particular are only a selection. We will be happy to design something new specifically to your request!

Please contact us in writing or by telephone with information about your required torque, the screws used and possible details about your application.
e-mail: sales@juwel-schraubtechnik.de | +49 (0) 2742 - 96 8 96 - 0

If you have any questions, we will contact you so that we can offer you the right torque wrench. Optionally, we can perform a free demonstration and make a technical recording of your bolted joint. We are also ready at any time to exchange STEP models.

All details have been clarified? We will provide you with a transparent offer including any 3D models/drawings of your power wrenches and accessories.

After your approval, we start processing the order: We deliver standard units after 1-2 weeks (also available from stock at short notice). Special solutions are usually delivered after 2-4 weeks.

Our motivation does not end with the delivery: we conduct training courses and support you with further equipment or accessories. In addition, we are your loyal contact for questions on the subject of bolting. We also carry out calibrations and repairs.

OUR SERVICES

Die Verschraubung - branchenunabhängig findet sie Ihre Anwendung. Genau das macht unsere Arbeit und unsere Produkte so spannend. Es gibt Schraubfälle wie aus dem Lehrbuch: Drehmomentschrauber, Standardabstützung und Aufstecknuss: Alles passt. Doch hin und wieder ist es nicht so einfach. Wo kann abgestützt werden? Wie viel Platz habe ich für die Aufstecknuss? Wie eng ist die Schraubumgebung? Unabhängig davon gilt, ob Standard oder Sonderlösung: Wir stehen eng an Ihrer Seite und versuchen alles möglich zu machen. Dazu kommen wir kostenfrei bei Ihnen vorbei, erfassen Ihren Ist-Zustand und machen uns anschließend an die Arbeit. Unsere firmeneigene Konstruktions- und CAD/CAM-Abteilung erarbeitet eine spezifische Lösung und unser Vertrieb berät Sie gerne. Nach dem Kauf hört unser Service noch lange nicht auf: Schulungen, Ersatzteil- und Reparaturservice (auch von Fremdfabrikaten) und Kalibrierungen - alles aus einer Hand. Dabei kennen wir keine Wartungsfristen: Auch über 20 Jahre alte Geräte werden weiterhin repariert und instandgesetzt.



Engineer to Order

Thanks to our in-house CNC production, we manufacture products according to your requirements: reaction arms, nuts, side drives, screw carriages and much more.



Consultation on site

Sometimes the best brochure and the most detailed homepage are just not enough: We will be happy to demonstrate our torque wrenches free of charge on your premises.



Calibration and repair

The first calibration is free of charge. Turnaround times for our workshop service are 7 working days (faster in an emergency) - transitional equipment is available. Each unit is completely checked and the gear cleaned during calibration.



Certified JUWEL quality

All mechanical components are manufactured in Wissen an der Sieg in Rhineland-Palatinate. With the TÜV certification according to DIN ISO 9001, we successfully undergo an external audit of our quality standards every year.

Calibration and repair

Calibration and repair service for electric, hydraulic, pneumatic and mechanical torque wrenches, of course also for third-party devices. All screwdriving devices receive a torque table resulting from the testing of the respective device. The enclosed test reports document the exact torques. The measured data are presented numerically and graphically in a standardised protocol. The testing of the continuously rotating nutrunners is carried out according to ISO-5393. Each unit is completely checked and the gear cleaned during calibration.

We do not know any maintenance deadlines: Even devices that are more than 20 years old are checked and serviced. After receiving a torque screwdriver, it is completely checked by us for its functionality and cleaned. The subsequent calibration and replacement of any wearing parts enables you to use it reliably again.

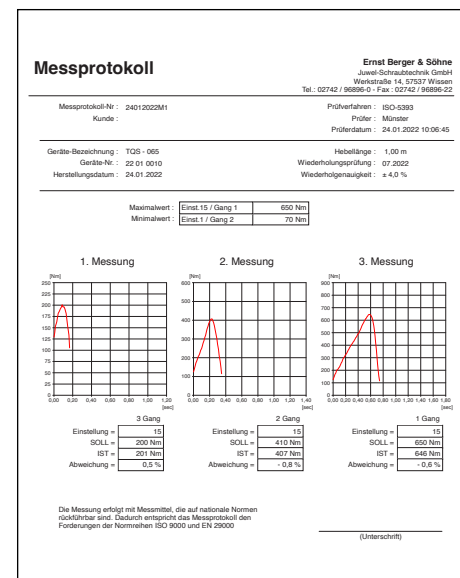



Rental service

Do you only screw occasionally? Do you have a temporary construction site or are you carrying out revision work? All torque wrenches including accessories are also available for rent. Benefit from individual rental offers: With us, renting is worthwhile from day 1.

You decide to buy the unit within 6 months after the rental? We will reimburse you up to 50% of the new price according to your previous rental costs. *Example: You have rental costs of € 2,500 and would like to purchase a new unit for € 4,000. Benefit from a 2,000 € discount and only pay 2,000 € for the new purchase.*

Flexible payment methods

Within the DACH region, you pay conveniently on account. Outside this economic area, you make the first transaction on prepayment. If everything goes smoothly, we will switch to purchase on account here as well. You need the tool immediately, but do not want to or cannot make the payment in full directly? We offer you an installment purchase, financing or leasing of our torque wrenches - with or without a third party involved.



Bolting service

Do you have a one-off bolting case? We will visit you on site and carry out the bolting for you. Of course, we have the necessary accessories in our luggage.



Online demonstration

The world has moved on. Even though there is no substitute for a personal demonstration, we are also making use of the technical possibilities: From now on, flexible demonstrations via video call.

CONTACT

Do you have questions about bolting? Do you need a torque wrench or accessories? Contact us - we will be happy to advise you and carry out a free demonstration at your premises.



Ernst Berger & Söhne **JUWEL** - Schraubtechnik GmbH

Werkstraße 14 | 57537 Wissen - DE
info@juwel-schraubtechnik.de | +49 2742 96 8 96 - 0